

Block Diagram and Description of Maxim's TDD-WCDMA Transceiver Solution at 1.9GHz

This application note presents the block diagram for Maxim's TDD-WCDMA transceiver solution. The direct conversion receiver eliminates one SAW filter. Fast DC offset cancellation supports fast settling time. The operating frequency range is 1900 to 1920MHz. The transmitter achieves EVM of better than 7.5%.

Overview

TDD-WCDMA (time division duplex- wideband code division multiple access) is the third-generation (3G) cellular phone standard adopted by 3GPP. Several frequency bands, such as 2.0GHz, 1.9GHz and 800MHz, have been assigned for these applications.

Since TDD-WCDMA employs Time Division Duplexing and no TX-RX (transmit-receive) frequency separation is required, it makes the frequency band's availability much more flexible in spectrum-limited areas.

In the radio section of the handset, the TDD-WCDMA radio requires fast settling time, high dynamic range, low current consumption, and high linearity in both the transmitter and receiver sections. Maxim's Zero-IF chipset delivers the highest performance, the smallest implementation size, and the least expensive radio solution available in the TDD-WCDMA handset market. The following block diagram shows a typical application.(See Figure 1.)

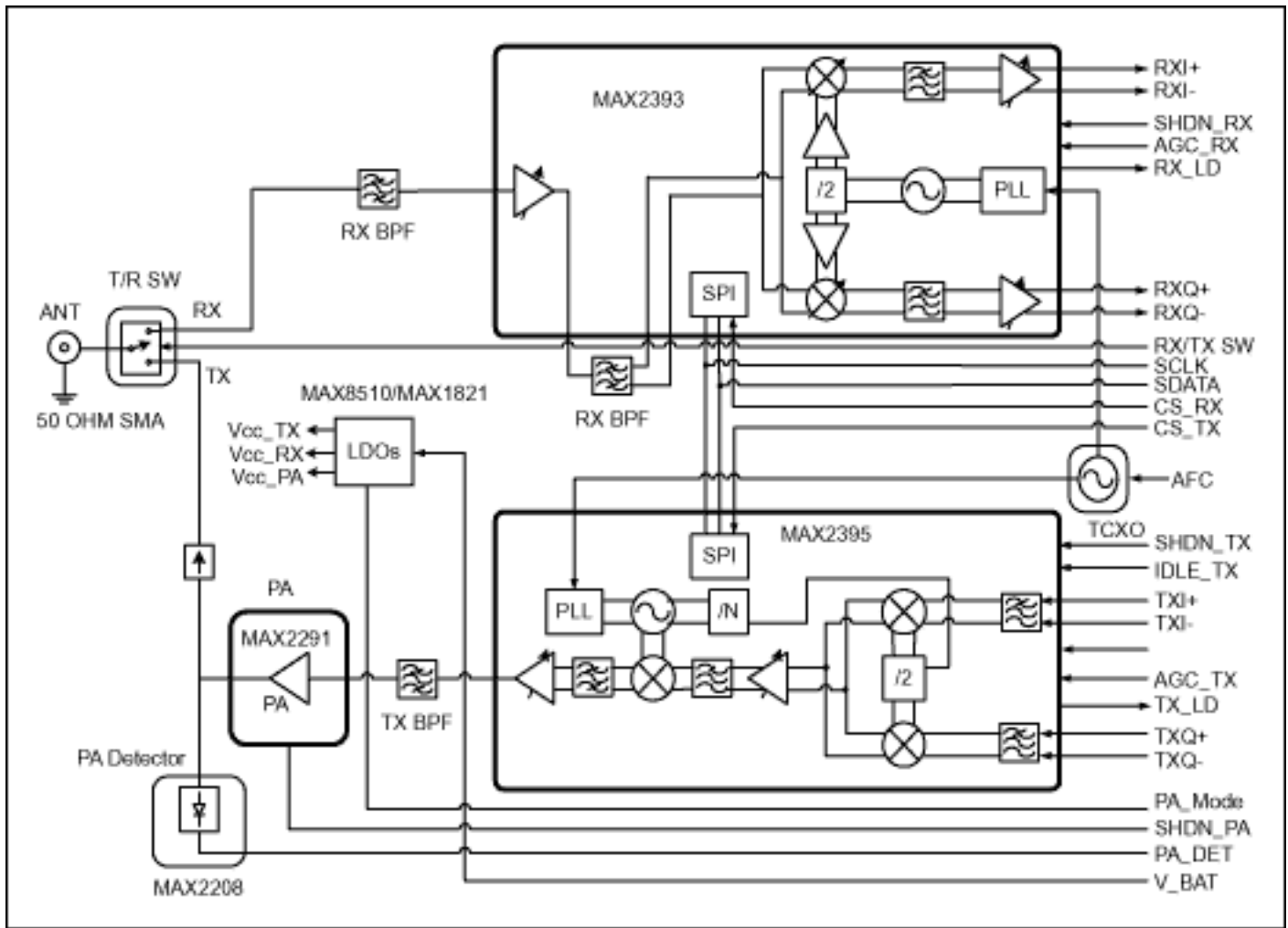

Figure 1.

Transmitter

The MAX2395 is a fully monolithic quasi-direct modulator IC for use in WCDMA/UMTS transmitters. The quasi-direct modulation architecture reduces system cost, component count, and board space compared to transmitters using IF SAW filters, IF VCO and IF synthesizer blocks. It includes I/Q baseband filters, an IF I/Q modulator with VGA, a fully monolithic VCO with PLL, a up-convert mixer with VGA, and a power amplifier driver. It is the ideal transmitter for TDD-WCDMA because of these features:

- Frequency range: 1900-1920MHz
- Output power of +8dBm with -45dBc ACPR
- Minimum 82dB power-control range
- On-chip RF PLL, with fully monolithic VCO and tank
- 30dBc minimum carrier suppression
- 35dBc minimum sideband suppression
- No need for IF SAW filter
- EVM \leq 7.5% for Pout: +8dBm to -44dBm
- Low-noise power during the power-down mode
- Offered in QFN 28-"pin" leadless package (5mm x 5mm)

Power Amplifier

The MAX2291 is a linear amplifier optimized for 1.9GHz TDD-WCDMA application. It can deliver +26dBm output power with 30% power-added efficiency (PAE) and 37dBc ACLR1. To improve efficiency at medium output power, the PA power supply, Vcc_PA, is driven at reduced voltage using a low drop out switching regulator, the MAX1821.

Receivers

The MAX2393 is a fully integrated direct-conversion receiver for 3GPP TDD-WCDMA applications. It provides a complete receiver solution from antenna to baseband I&Q outputs, eliminating the use of an off-chip IF SAW filter and of external RX LO generation and synthesis. In the MAX2393, channel bandwidth selection (1.92MHz / 0.64MHz) is done on-chip electronically. It consists of an ultra-low current LNA with on-chip output matching and two-step gain modes. The zero-IF demodulator has a differential circuit topology for best input IP2 and for minimum LO leakage to receiver's input. The channel selectivity is done completely in the baseband section of the receiver with an on-chip low-pass filter. The DC-offset cancellation in the I/Q baseband channels is done fully on-chip using a DC servo loop connected over the AGC section. For large DC-offset transients, very fast settling time is obtained by automatic optimization of the time-constant of the DC-offset cancellation circuit. The key features of the MAX2393 are as follows:

- Frequency range: 1900-1920MHz
- Low Operating Supply current: 33mA at High Gain mode
- NF (Noise Figure, in High Gain mode): 3.0dB DSB (double side band)
- On-chip RF PLL, with fully monolithic VCO and tank
- High dynamic range: Over 90dB of gain control
- Voltage gain (High Gain mode): 100dB
- Input IP3 (High Gain mode): -16.5dBm
- Input IP2 (High Gain mode, 15MHz offset): +22dBm
- LO Leakage (at LNA input): -74dBm Max
- No need for IF SAW filter
- Adjacent channel selectivity: 55dB
- No need for IF SAW filter and off-chip RF VCO module + PLL Synthesizer
- Offered in QFN 28-"pin" leadless package (5mm x 5mm)

More Information

MAX1821: [QuickView](#) -- [Full \(PDF\) Data Sheet](#) -- [Free Samples](#)

MAX2393: [QuickView](#) -- [Free Samples](#)

MAX8510: [QuickView](#) -- [Full \(PDF\) Data Sheet](#) -- [Free Samples](#)